

WYBOT

Robotic Pool Cleaner User Manual

WYBOT S2Pro(WY210)

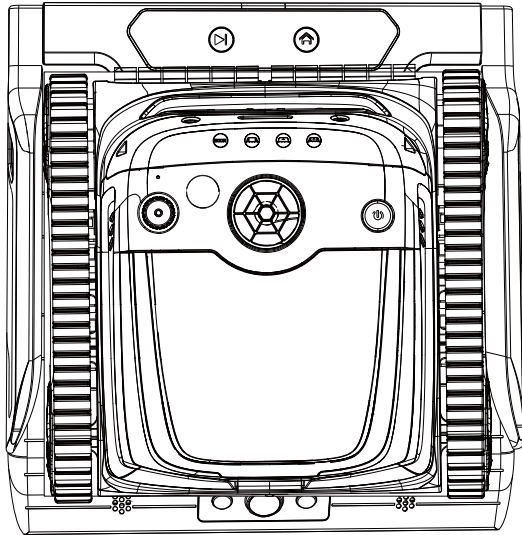

EN

Read through the entire manual before running your new robotic pool cleaner, and keep this manual handy for your reference.

WYBOT

www.wybotpool.com

E-mail: support@wybotpool.com

Facebook: @WybotPool

WYBOTICS CO.,LTD

No.30,Zhongnan 4th Street West Zone,TEDA Tianjin,China

All trade names are registered trademarks of respective manufacturers listed.



WYBOT

Thank you for choosing WYBOT products, your support means a lot to us. Continuous providing the best solution to free you up from pool cleaning and enjoy your family time is always our pursuit.

WYBOT Robotic Pool Cleaner is dedicated to serving you high efficiency, low power consumption, easy operation and thorough pool cleaning work.

Its unique appearance and reliable functions as one-button activation, powerful suction and scrubbing, fine filtration, smart navigation, remote control, and high compatibility with various pool shapes and constructions materials assure you a convenient, intelligent, and optimal pool cleaning.

Feel free to contact us by Email or visit our website with any questions. We are very glad to hear your advice on our continuous improvement.

Read the manual carefully before you use the cleaner. Your safety is the most important thing. Please read through and operate the device as per instructions, WYBOTICS Co., Ltd. is not held liable for any loss or injury caused by improper use.

Warning

Failure to operate the device as per the warnings can result in serious injury, electrocution or death.

1. Use only the accessories recommended or sold by WYBOTICS Co., Ltd.
2. Use only the original and authorized charging station. Avoid charging any other types of devices with this station. Improper use may result in overheating or corrosive liquid leakage from the battery.
3. Cut off power supply when doing any maintenance or removing it from the pool.
4. In case of any abnormal operation from the charging station, cut off the power supply immediately, and remove the robotic cleaner from the station. Contact professionals at once.
5. Make sure the electrical outlet is protected by a ground fault circuit interrupter (GFCI) and an earth leakage interrupter (ELI).
6. Do not use a cord-damaged charger to avoid any electrical shock.
7. Do not try to use nonauthorized extension cord to connect the charger to the station.
8. Never allow children to ride on the cleaner/docking station or play with them as toys.
9. Do not allow child to operate or maintain the device or docking station.
10. Do not enter the pool when the cleaner is working in it.
11. Never expose or charge the device in flammable environments.
12. Only licensed professionals can disassemble the sealed parts of the cleaner/docking station.
13. Do not operate the cleaner while pool filter is running.

Caution

Failure to operate the device as per the warnings can cause a damage to the device or personal damage.

1. Firmly stick the station hook onto a flat wall with the tape included.
2. If the pool liners comes away or is damaged, please repair it before sticking the charging station on the wall.
3. Fully charge the unit before first use.
4. Do not over charge the cleaner, which will reduce the battery life.
5. Charge the cleaner prior to being stored for a long time (over 6 months) to maintain an optimal battery life.
6. Remember to wash and clean the filter basket after each use.
7. Store the cleaner in a cool and ventilated place, away from direct sunshine or any heat source.
8. Use only the pool cleaner in the following water conditions:

Chlorine	Max 4 mg/L
pH	7.0 - 7.8
Temperature	41 - 95 °F (5 - 35 °C)
NaCl	Maximum 5000 PPM

CONTENTS

WYBOT S2PRO(WY210) AT A GLANCE	01
Product External Overview	01
Product Internal Overview	02
Packing List	02
INSTALL YOUR DOCKING STATION	03
GET STARTED	04
Charge your new WYBOT S2Pro(WY210)	04
Setup your new WYBOT S2Pro(WY210)	06
<i>Connect to your App</i>	07
<i>Choose your cleaning mode</i>	07
Run your new WYBOT S2Pro(WY210)	08
DO A FILTER CLEANING	09
PUT IT BACK TO DOCKING STATION	10
HOW TO DETACH THE DOCKING STATION	11
DEVICE SPECIFICATION	12
LIMITED WARRANTY	12
HOW TO MAINTAIN YOUR DEVICE	13
FAQ & TROUBLE SHOOTING	13
CERTIFICATION	15
WYBOT CUSTOMER CARE	15

WYBOT S2PRO(WY210) AT A GLANCE

Product External Overview

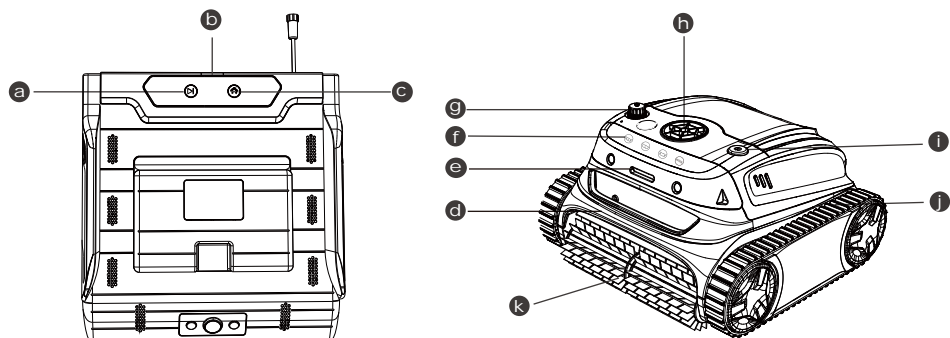

- a Start/Stop**
Press to start/stop pool cleaning
- b Indicator**
Indicate status of the docking station
- c Home**
Press to call the cleaner back
- d Handle**
Remove and transport the device with it
- e LED Indicator**
Different light colors to indicate device status
- f Cleaning Mode**
Customize cleaning needs on the cleaner
- g Charging Port**
Connect the charger
- h Pump**
pump out water through the window
- i on/off Button**
Turn on/ turn off the device
- j Track**
Enhance device's capability in climbing walls and various obstacles
- k Scrubbing Brush**
Knock loose all dirt and roll them all into the device

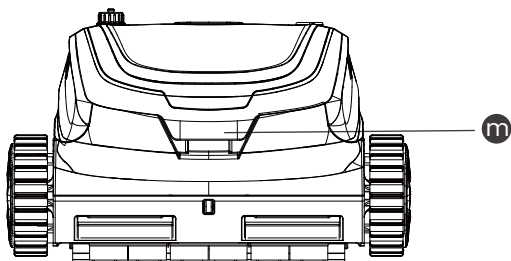

- m Lid Open Button**
Open the cover to take out the filter basket

Product Internal Overview

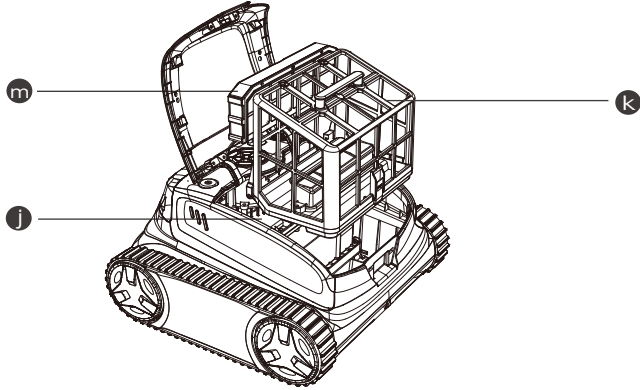



j Sealed Part
 Important components are sealed there. For your safety, do not try to disassemble it without authorization.

k Filter Basket (180µm)
 Store collected dirt and debris, need to be installed before cleaning, and washed after each use.

m Filter Foam (Cotton foam)
 An auxiliary filter to help trap the fine dirty particles. Recommend to use it for floor cleaning. Please do not install it when the pool water is heavy dusty, it may influence the operation of the cleaner.

Do not operate the device when the top cover or scrubbing brushes are broken. If there is any liquid leakage from the sealed part, stop charging or running the device.

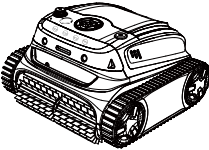
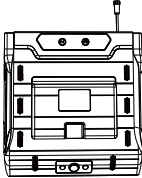
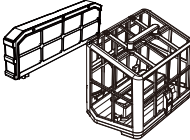
Packing List

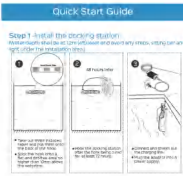
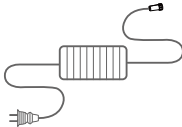
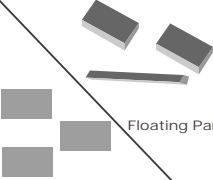
 <p>Device x 1</p>	 <p>Docking Station x 1</p>	 <p>Filter x 2</p>	 <p>Hook x 1</p>
 <p>User Manual x 1</p>	 <p>Quick Start Guide x 1</p>	 <p>Charger x 1</p>	 <p>Floating Parts Adhesive Tapes</p>

INSTALL YOUR DOCKING STATION

WYBOT S2 Pro is equipped with a docking & wireless charging station that you can find in your package.

You need to install this station onto your pool wall to create a good working condition for WYBOT S2 Pro. Please follow below steps.

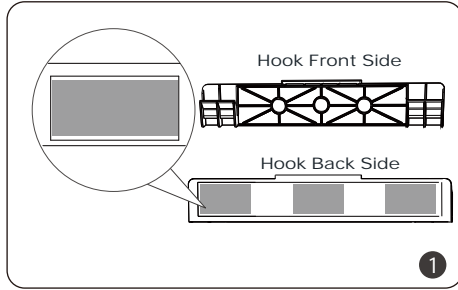

Take out three included adhesive gel nano tapes, and stick them onto the marked area on the station hook back side.

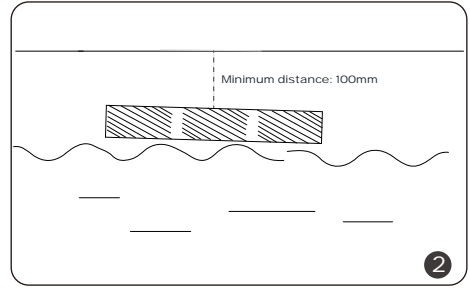

Find a flat wall 20mm above the waterline with a smoother surface and less dirt. Use a cloth to dry the surface. Ensure the area is not smaller than the hook.

Note:

1. This charging station is suggested to be stuck onto a flat and smooth wall surface, rough surface such as pebble material may not work very well.
2. The station hook bottom shall be 20mm higher than the waterline.
3. The water depth of the installation area shall reach 1.2m at least, and there should be no steps, sitting area or light under the docking station.

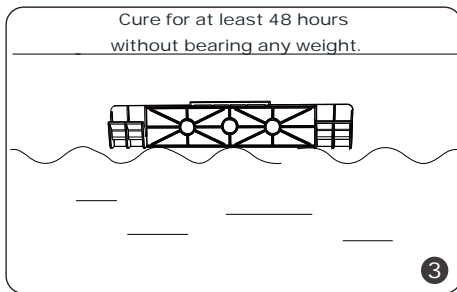

Adhere the station hook onto the tape that you have stuck firmly and horizontally.

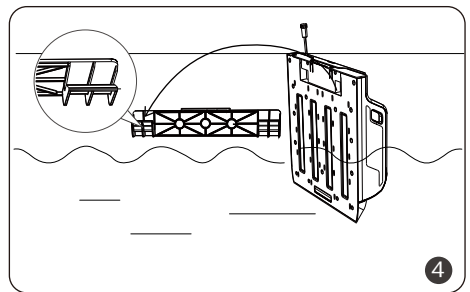

Place the main body of the station onto the hook.

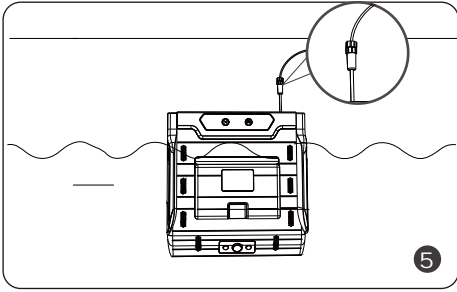

Insert the included extended charging line to the socket on the line of the station.

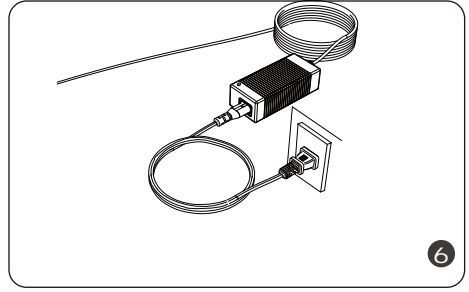

Stretch out the charging line and plug the adaptor into a power outlet that should be at least 3.5m(11.5ft) away from the pool.

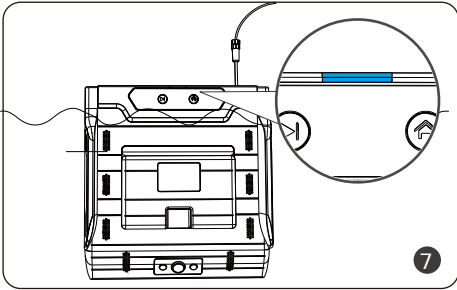

Plug the adaptor into a power supply, and the LED indicators turn solid blue.

Note:

1. It is highly recommended to install the docking station of the WYBOT S2Pro onto a pool wall of regular shape pool, otherwise it may affect the working of it.
2. Double check the connections before starting the cleaning.

GET STARTED

Charge your new WYBOT S2Pro(WY210)

The device has a lithium-ion rechargeable battery, and you need to charge the battery before first use or when the battery is low.

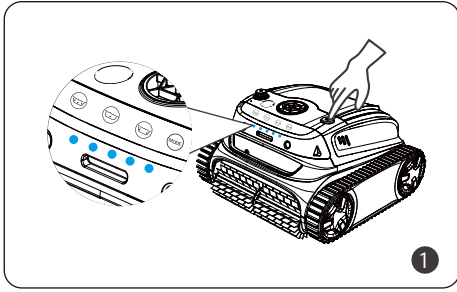

Turn on the device and the indicators on the front turn solid blue.

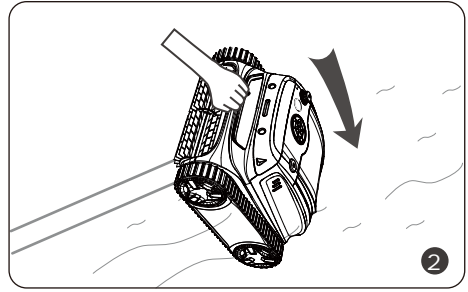

Hold the handle of the cleaner, and put it into the pool vertically.

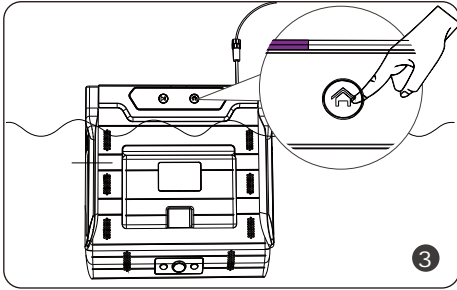

After 20s of self-calibration of the cleaner, press the home button to call it back to the docking station.

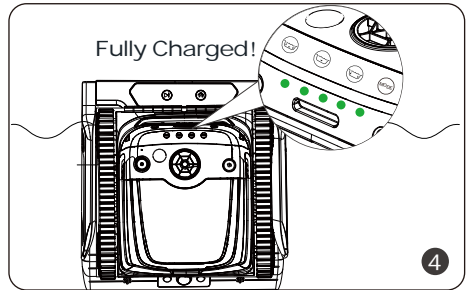







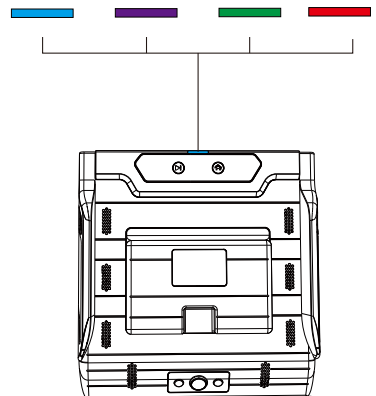
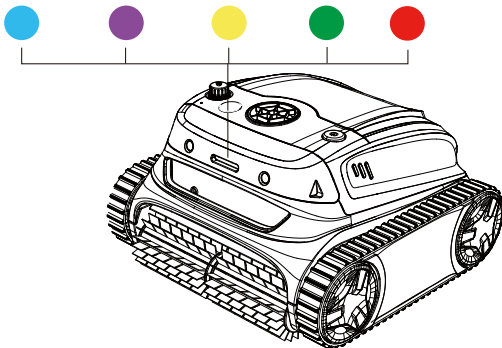

Start to fully charge itself automatically.

Note:

- 1. For reducing fire risk, keep your docking station beneath the water when starting charging.
- 2. No charging devices on shore using docking station.



Device	LED Light	Indication	Status
Robotic Pool Cleaner		Solid	Power On
		Flashing	Under working
		Solid	Connecting to App
		Flashing	Low battery or under self-parking in the pool
		Breathing (bright to dim)	Self-parking completion
		Solid	Battery Level
		Solid or flashing	Fault
Docking Station		Solid	Power On
		Solid	Able to control the robot
		Flashing or Solid	charging
		Solid or flashing	Fault

Note:

1. For maintaining a favourite working status, you need to keep the docking station always being powered on.
2. When yellow light flashes, the robotic pool cleaner will back to the docking station for the inductive charging.
3. If red LED light is on, you can find solution from trouble shooting in this manual or call for service.

Setup your new WYBOT S2Pro(WY210)

Connect to your App

You can download the WYBOT App to your smart mobile device by scanning QR code below, or from Google Play or App Store.

	iOS	Android
	iOS 15.0 or later	Android 8.0 or later





Note:

Before connection to your App, please ensure your cleaner is charging on the docking station.

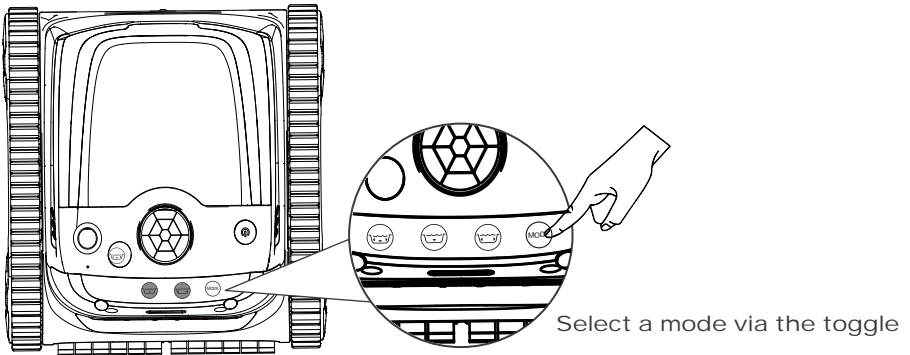
Choose your cleaning mode

You can choose a cleaning mode for your cleaner on the device or through the app after connecting to your App.



Icon	Indication
	Toggle a cleaning mode
	Wall*1 then floor*1 (default) There are two types of full-pool cleaning in the app, you can customize this icon there.
	Pool floor cleaning There are three types of floor cleaning in the app, you can customize this icon there.
	Pool walls cleaning

Note:

1. There are more cleaning mode options in the app, and you can refer to it below.

Mode	Cleaning Coverage
Standard Full Pool	Wall+ Floor+Waterline
Floor Only	Pool Floors
Wall Only	Pool Walls
Waterline	Pool Waterline
Wall then floor (Combo)	Wall *1+ Floor *1
Eco floor	Eco mode, floor cleaning only
Turbo Floor	Strong cleaning, floor cleaning only

2. You should modify your cleaning modes via App when out of pool.

3. If the device restarts, it will automatically enter the cleaning mode you set last time.

Run your new WYBOT S2Pro(WY210)

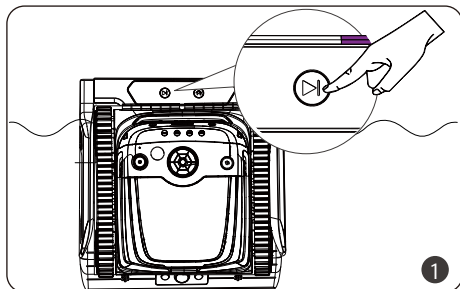

Press the start/stop button on the docking station or click the start cleaning button to start the pool cleaning.

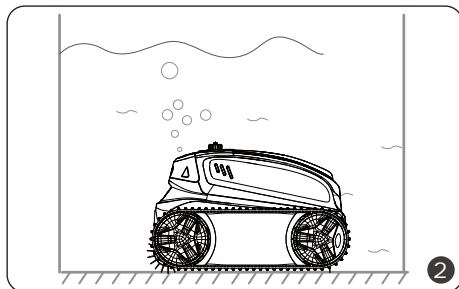

Let it move back to the pool floor.

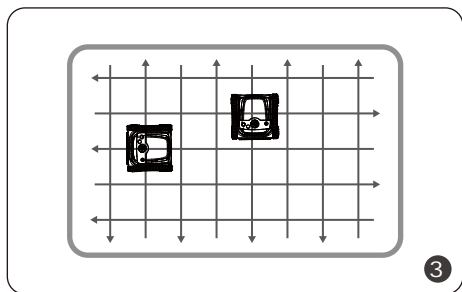

The cleaner begins to clean walls, floor and waterline as default or your set through App.

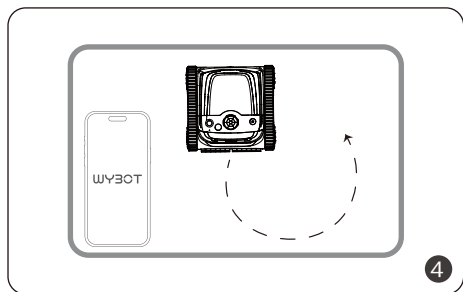

You can control the cleaner remotely and complete the specific area cleaning via the App.

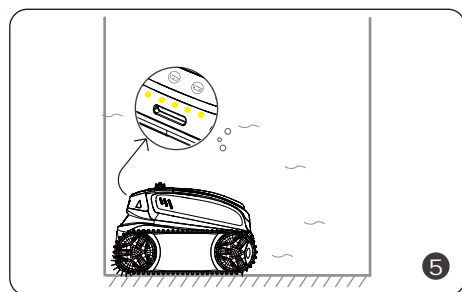

The device will automatically move to the docking station when finishing cleaning or battery is low.

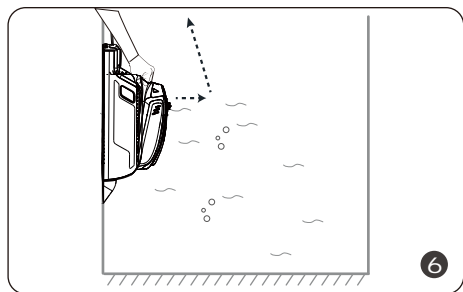

Remove the cleaner from the docking station and power it off.

DO A FILTER CLEANING

Press the filter cover handle and lift the cover up.

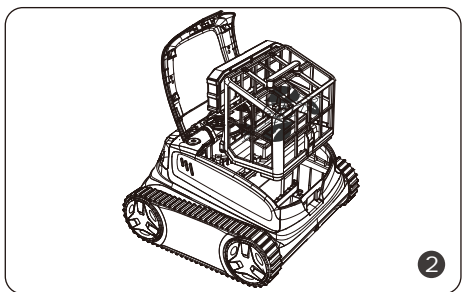
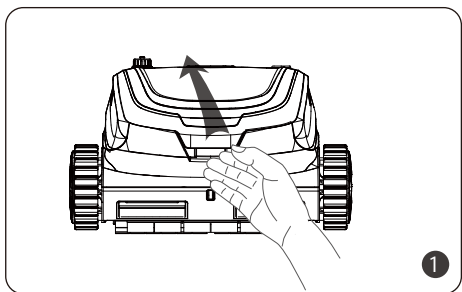

Note:

1. You should ensure the device is power off when open the top cover.
2. You need to clean the filter basket after each use.

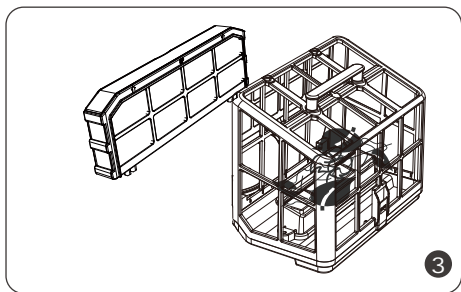

Take out the filter basket and cotton foam.

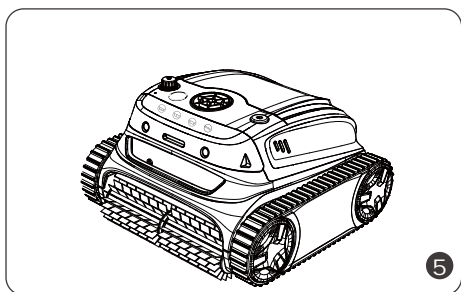

After rinsing, put the filter basket and cotton foam into the cleaner and close the cover.

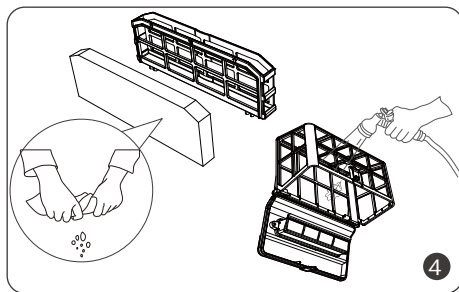

Empty all debris and rinse it with clean water.

- As electric components inside the cleaner, store the cleaner in a cool and ventilated place, away from direct sunshine or any heat source.
- Charge the cleaner prior to being stored for a long time (over 6 months) to maintain an optimal battery life.

PUT IT BACK TO DOCKING STATION

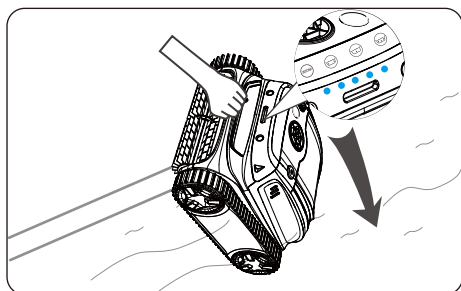

Turn on the device and put it into the pool vertically.

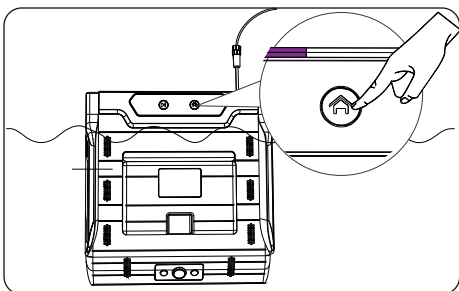

Press the home button to call the cleaner back to the docking station.

If your cleaner is powered off because of the low battery, you can put the cleaner onto the docking station manually.

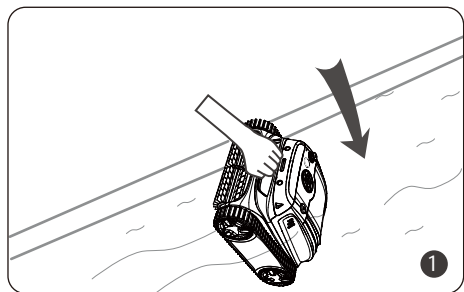

Hold the handle of the cleaner, and emerge it into pool water vertically.

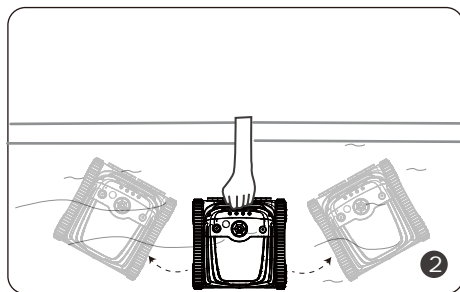

Shake the cleaner horizontally to empty trapped air inside.

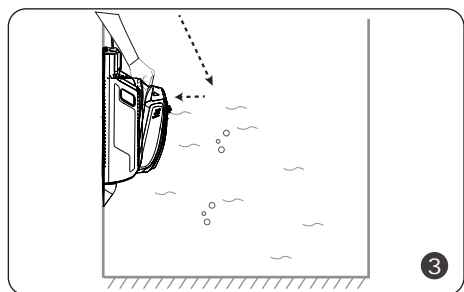

Put the cleaner onto the docking station carefully or put it into the pool and call it to the docking station.

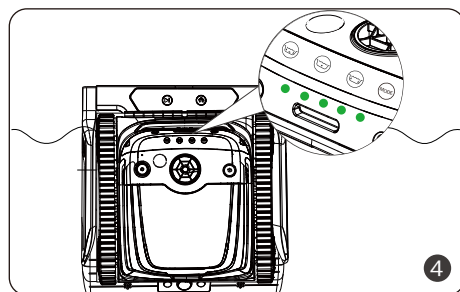

Start to fully charge itself automatically and keep standing by for next cleaning cycle.

HOW TO DETACH THE DOCKING STATION

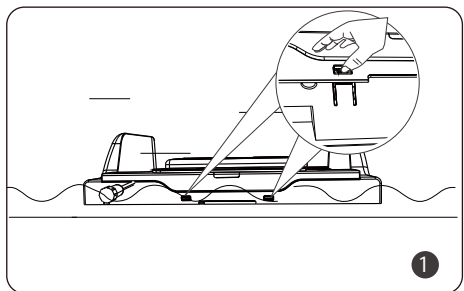

There are two small fasteners on the top of the docking station, and you can push them to remove the main part from the hook.

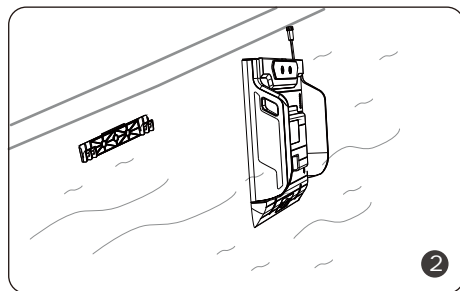

Detach it successfully.

Note:

1. As electric components inside the docking station and cleaner, store the cleaner in a cool and ventilated place, away from direct sunshine or any heat source.
2. Charge the cleaner prior to being stored for a long time (over 6 months) to maintain an optimal battery life.

DEVICE SPECIFICATION

Model	WYBOT S2Pro (WY210)
Pool Size	Up to 300m ² (3229.173ft ²)
Depth	9.8ft (3m)
Device Dimension	400(L)*390(W)*255(H) mm ^{157(L)*154(W)*100(H)} inch
Weight	8.5 Kg (Robotic cleaner)+3.3Kg (Station)
Runtime	3.5 hours
Charging Time	3 hours (direct charging)
Voltage	Battery/25.9V
Power	90W
Charger Input	100-240V, 47-63Hz
Charger Output	29.4V/3A
Battery Capacity	7800mAh
Filtration	Double-level
Flow Rate	14m ³ /H (3962GPH)
Moving Speed	10m/min.
Water Resistance	IPX8
OTA upgrading	Available
App Connection	Available

LIMITED WARRANTY

1. All WYBOT pool cleaners in the market have been inspected and licensed to be sold as per local laws.
2. The warranty duration for battery, motor and PCB is two (2) years from the purchasing date. Consumable parts, including filter basket, brush, wheels etc., are beyond warranty.
3. The warranty apply only to original buyers, and not valid to resale and any other kinds of transfer.

4. Any damages to the unit caused by improper use, unauthorized repair or disassembly are not covered by WYBOTICS Co., Ltd.'s warranty.
5. The order number or record must be presented for any claim or repair within the warranty period.

HOW TO MAINTAIN YOUR DEVICE

You should follow the steps to store your cleaner to maintain good performance.

- a) Ensure the device is power off
- b) Dry out the cleaner and filter basket
- c) Fully charge the battery
- d) Store the cleaner in a cool and ventilated place, away from direct sunshine, heat source, frost and squeezing with an ambient temperature between 5°C / 41°F and 45°C / 113°F.
- e) Charge the cleaner every three months to ensure an optimal battery life.

Note:

If your device do not work after a long-term low battery life or being off, please contact after-sale team for help. For your safety, do not try to disassemble it without authorization.

FAQ & TROUBLE SHOOTING

Q: What pool shapes and construction materials is the cleaner suitable for?

A: The machine can be applied to rectangle, oval, or irregular shapes of in-ground swimming pools. Applicable construction materials include PVC, guinite, tile and other materials.

Q: Will obstacles such as steps, shallow water areas, drains, slopes etc. in the swimming pool affect the running?

A: The machine can climb steps, drains, and shallow water areas. The above obstacles may influence its cleaning path, but will not affect the operation of the machine.

Q: Are the WYBOT App able to control the device when cleaning under water?

A: Since the signal can not be transferred under water, you need to preset the cleaning mode and cleaning path before put into the pool.

If you encounter the following situations when using the cleaner, you can check the table and solve them by yourself.

Note:

If you can not find a solution from the table, please contact after-sale team.

No.	Issues	Details	Possible Causes	Suggested Solution
1	Cannot charge	All LED indicators show green	Sealed parts or charger are damaged.	Contact for change.
		No LED indicators show	The device does not have a good contact with the docking.	Adjust the position.
2	Charger light dies	Plug into the power supply well, but no light shows.	The charger is damaged.	Contact for change.
3	Cannot be turned on	No LED indicators show	Low battery.	Charge the device.
4	Does not work	LED indicators die after a while.	Automatically power off 3 min after no operation.	Relaunch the device.
		Show solid red light	Impeller or filtration basket is stuck.	Open to clean.
		Show flashing red light	Overheat protection.	Relaunch the device after a while.
		Show flashing yellow light	Low battery.	Charge the device.
5	Cannot clean the wall	Wrong cleaning mode.	Choose wall cleaning mode.	
		Heavy dirty pool water.	Clean filtration system.	
		Use cotton foam.	Remove cotton foam.	
		Gyro need be calibrated.	Calibrate it using the App.	
		Device weight it heavy.	Install floating parts.	
6	Low cleaning coverage	Firmware is not the latest version.	Update it using the App.	
		Floor cleaning mode	Switch to full-pool cleaning.	
7	The front part raises frequently	Full filtration basket	Clean filtration system.	
8	Cleaning path is not patterned	Gyro need be calibrated.	Calibrate it using the App.	
9	The device is stuck at main drains or floor lights	The obstacle is high than 30mm (1.2ft)	Manually unstuck the device.	
10	Cannot call the device back to the docking station.	No power supply for the docking station	Connect to the power supply.	
		The docking station need be calibrated.	Contact for calibration.	

CERTIFICATION

WYBOT robotic pool cleaners have passed all performance and reliability tests and also has obtained relevant certifications from the countries in which they are sold. you can rest assured.

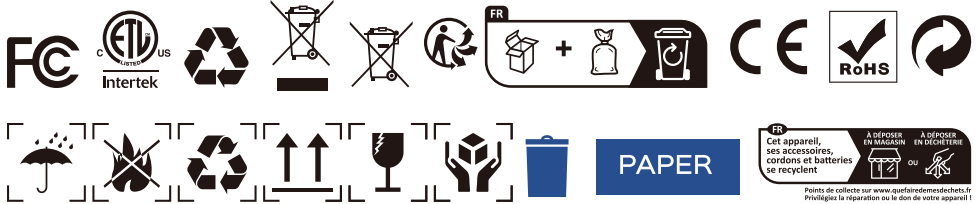

WYBOT CUSTOMER CARE

Due to the need for continuous products improvement, the products in the manual are subject to the real products, and WYBOTICS Co., Ltd. reserves the right to update products.

If you encounter any problems during use, please contact after-sale team. For more details, please contact WYBOTICS website www.wybotpool.com

Wybot Customer Service:

Email: support@wybotpool.com

Facebook: @WybotPool

Tel: 1-866-777-6655

